

# WOOD'S POWR-GRIP® MANUAL ROTATOR/ TILTERS

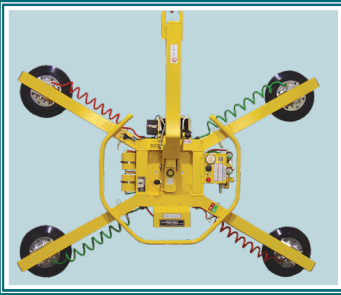

**MRT411LDC**  
700 lbs [320 kg]

**MRT49DC**  
500 lbs [225 kg]

**MRT4HV11DC**  
600 lbs [270 kg]

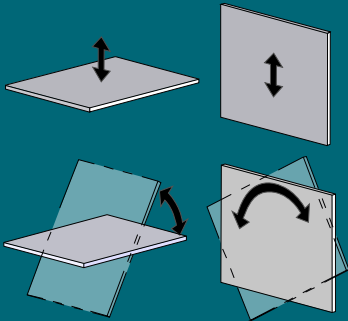

**THE ORIGINAL  
& TRUSTED NAME  
IN VACUUM LIFTING  
EQUIPMENT**

**800.548.7341**  
**WPG.com**

908 West Main - P.O. Box 368  
Laurel, Montana 59044 U.S.A.  
406.628.8231 (phone)  
406.628.8354 (fax)



Wood's Powr-Grip products are sold through authorized dealers.

With three frame configurations, 90° tilt and continuous 360° rotation, these Powr-Grip® vacuum lifters deliver maximum versatility and range of motion in the shop or at the construction site.

	<b>MRT411LDC</b>	<b>MRT49DC</b>	<b>MRT4HV11DC</b>
<b>Maximum Load Capacity</b>	<b>700 lbs [320 kg]</b>	<b>500 lbs [225 kg]</b>	<b>600 lbs [270 kg]</b>
<b>Standard Pad Spread</b>	28¼" x 32¾" [717 x 834 mm] (basic configuration) 48¼" x 67½" [1227 x 1716 mm] (extended configuration) 78¼" x 15¾" [1988 x 398 mm] (linear configuration)	25¼" x 30" [642 x 760 mm] (basic configuration) 45¼" x 64¾" [1152 x 1643 mm] (extended configuration) 75¼" x 12¾" [1914 x 323 mm] (linear configuration)	27¼" x 31¾" [693 mm x 807 mm] (basic configuration) 47¼" x 66½" [1201 mm x 1690 mm] (extended configuration) 77¼" x 14½" [1963 mm x 369 mm] (linear configuration)
<b>Number / Size of Pads</b>	4 / 11" [28 cm] dia. lipped	4 / 9" [23 cm] diameter	4 / 10" [25 cm] dia. lipped
<b>Load Movement</b>	Manual rotation, 360° edgewise, with locking at each 1/4 turn Manual tilt, 90° between upright and flat, with automatic latching in upright position		
<b>Standard Operating Power</b>	12 volts DC, 10 amps		
<b>Standard Features</b>	Low vacuum warning light Battery and charger Battery energy gauge Vacuum gauge Vacuum line filter Vacuum reserve tank Spring-mounted pads Movable pad mounts Extension arms		
<b>Available Options</b>	Dual vacuum system (MRT4-DC3) Forklift adapter (95722) Adaptable length lift bar (95723) Long extension arms (95725) Individual pad shutoffs (93011) Extensions for movable pad mounts (93101 & 93101AM) Pad frame T-arm assemblies (97466) Alternative vacuum pad compounds for low-marking, temperature resistant and coated surface applications (special order) Shipping case (53006)		
<b>Lifter Weight</b>	135 lbs [62 kg] (Note: does not include weight of any options)		
<b>Design Standards</b>	ASME B30.20 (BTH-1 Design Category "B", Service Class "0") CE AS 4991  (See www.WPG.com for more information)		

Based on product information at time of publication. Environmental conditions can affect product performance and longevity; consult the product instructions on WPG.com or contact a Technical Sales Representative for more information.

Basic Configuration



Linear Configuration

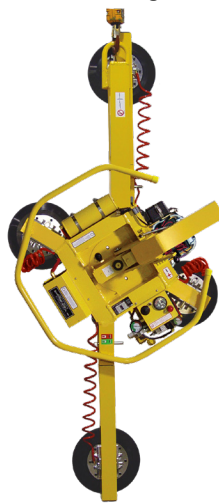

Extended Configuration

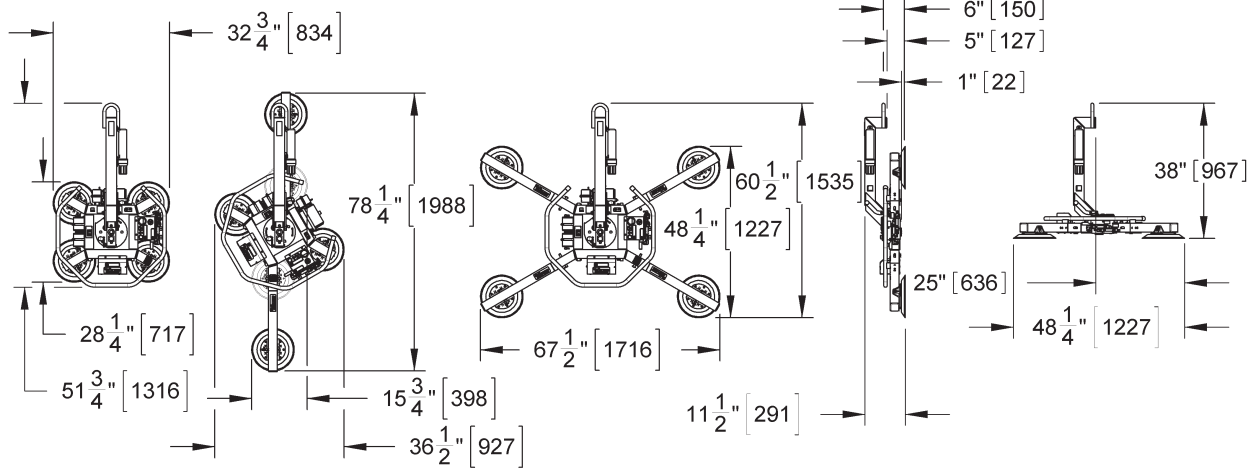

## SHIPPING CASE FOR MRT VACUUM LIFTER

(lifter and case sold separately)

- Designed specifically for shipping and storing Powr-Grip® MRT4 Vacuum Lifters.
- Made from 100% recycled HDPE plastic, features twin sheet, thermo-formed construction, making it very durable, as well as water-resistant.
- Special area to house extension arms for these lifters.
- Internal nylon straps to hold the lifter and extension arms firmly in place, preventing them from rattling around while in transit.
- Exterior rubber straps to hold the case securely closed during shipping.
- Handles molded into the case enable convenient handling.
- Mounting points inside the lid of the case enable the hanging of up to 4 extra vacuum pads.
- Ribbed exterior of case specifically designed for easy stacking of multiple lifters (up to 4).
- Wheels on one end make short distance movement of the lifter manageable by one individual.
- Grooves on the bottom of the case facilitate forklift handling from all four sides.



# MRT OPTIONS

## Adaptable Length Lift Bar

Designed for applications requiring increased horizontal reach at the hook point or applications involving minimal clearance between the lifter and the hoisting equipment, such as installations under eaves or similar handling situations.

**Overhead Clearance Reduction:** 11-3/4" [298 mm] with Shortened Configurations

**Horizontal Reach Increase:** 7-5/8" [193 mm] with Reversed Bail Configurations

**Maximum Load Capacity\*:**

Standard Configuration:	700 lbs [320 kg]
Reversed Bail Configuration:	600 lbs [270 kg]
Shortened Configuration:	650 lbs [295 kg]
Shortened, Reversed Bail Configuration:	500 lbs [225 kg]

\*Net capacity cannot exceed standard lifter capacity.

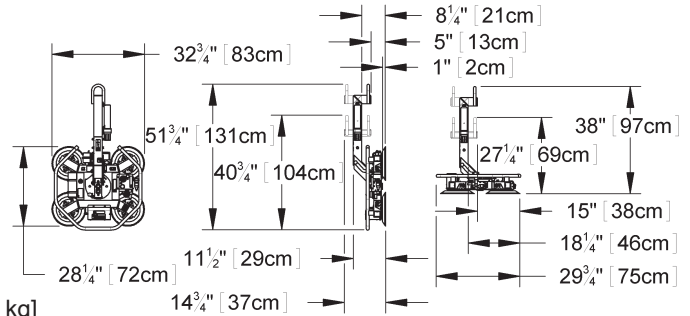

**Lifter Weight Increase:** 10 lbs [5 kg]

## Forklift Adapter

Designed for applications where a forklift is desired, such as installations under eaves and commercial, indoor applications, where using a crane is not possible.

**Compatible Fork Dimensions:** 1-1/2" to 2-1/4" [38-57 mm] thick and 4" to 6" [102-152 mm] wide

**Inside Fork Spread:** 4" [102 mm]

**Maximum Load Capacity:** 700 lbs [320 kg] when used on MRT411LDC\*

**Maximum Load Thickness:** 1" [25 mm] at full capacity

**Lifter Weight Increase:** 130 lbs [59 kg]

\*The forklift must have sufficient capacity for the combined weight of the lifter and its maximum load when the load is located 8-3/4" [222 mm] outward from the fork tips or 50-3/4" [1289 mm] outward from the fork stops, whichever places the load at a greater distance from the forklift's front wheels.

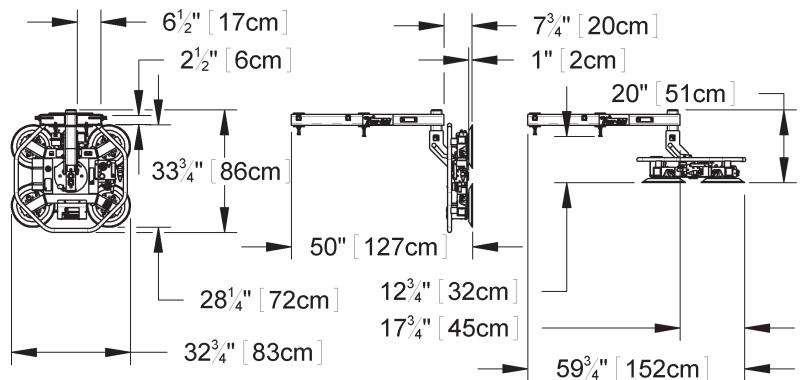

## Long Extension Arms

Designed for applications requiring a larger pad spread to reduce overhang on large loads.

**Maximum Load Capacity:** 500 lbs [225 kg] (with long arms installed)

**Pad Spread Dimensions provided are for MRT411LDC.**

For MRT49DC, subtract 2-3/4" [73 mm]  
For MRT4HV11DC, subtract 1-3/4" [48 mm]

**Lifter Weight Increase:** 10 lbs [5 kg]

