

WOOD'S POWR-GRIP® QUADRA-TILT ROTATORS 1200 & 1400 (DC) WITH DC3 DUAL VACUUM SYSTEM

Employing state-of-the-art technology, **Intelli-Grip®** automatically monitors vacuum and power systems to:

- Maximize productivity
- Help reduce human error
- Simplify maintenance and repairs
- Protect employees and property from harm



	MRTA811LDC3	MRTA810TDC3
Maximum Load Capacity	1400 lbs [635 kg]	1200 lbs [545 kg]
Intelli-Grip® Technology	Automatic self-testing ensures lifter is ready for use, every lift. Color display provides critically relevant information at a glance. Anticipates threats and alerts operator beforehand with clearly visible and audible warnings. Continuously monitors battery and prevents lifter from attaching to loads if energy is hazardously low. Multiple alarm levels plainly identify the severity of hazards.	
Load Movement	Manual rotation, 360° edgewise, with locking at each 1/4 turn Assisted manual tilt, 90° between upright and flat	
Standard Operating Power	12 volts DC, 4.5 amps	
Standard Features	Intelli-Grip® technology Dual vacuum system Battery and charger Battery energy gauge Low vacuum strobe light Low vacuum/power loss warning buzzer with back-up battery Green lift light Vacuum gauges Vacuum line filters Vacuum reserve tanks Spring-mounted vacuum pads (Re)movable pad mounts Pad extension arms Tilt locks Blow-off for quick release Two-action, push-button release	
Dual Vacuum System	Features two completely independent vacuum circuits. Provides vacuum system redundancy. Limits possibility of a catastrophic failure. Reduces chance of harm to personnel or equipment.	
Available Options	Remote control system (59906) Pad frame T-arm assemblies (97465 & 97465HV) Forklift adapter (95457) Alternative vacuum pads (Specifications not as listed above. Please contact us for more information): 9" [23 cm] diameter pad (VPFS9) 10" [25 cm] diameter, concave pad (G0750) 10" [25 cm] diameter with replaceable sealing ring (VPFS10T) Alternative pad compounds for low-marking, temperature resistant and coated surface applications (special order) Shipping case (53007) Available for lease	

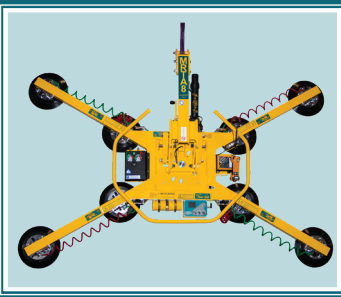

MRTA811LDC3
1400 lbs [635 kg]

MRTA810TDC3
1200 lbs [545 kg]

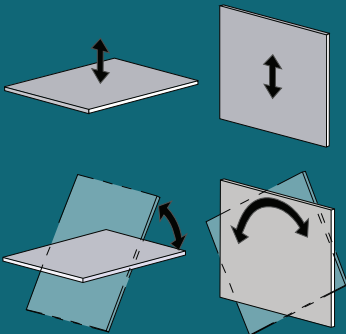

**THE ORIGINAL
& TRUSTED NAME
IN VACUUM LIFTING
EQUIPMENT**

800.548.7341
WPG.com

908 West Main - P.O. Box 368
Laurel, Montana 59044 U.S.A.
406.628.8231 (phone)
406.628.8354 (fax)



Wood's Powr-Grip products are sold through authorized dealers.

	MRTA811LDC3	MRTA810TDC3
Standard Pad Spread	Minimum Width: 12-1/2" [32 cm] Maximum Width: 58-3/4" [149 cm] Minimum Length: 47" [119 cm] Maximum Length: 104-3/4" [266 cm]	Minimum Width: 11-1/2" [29 cm] Maximum Width: 58" [147 cm] Minimum Length: 46" [117 cm] Maximum Length: 104" [264 cm]
Number / Size of Pads	8 / 11" [28 cm] diameter, lipped pads	8 / 10" [25 cm] diameter pads with replaceable sealing rings
Lifter Weight	200 lbs [91 kg]	
Design Standards	ASME B30.20 (BTH-1 Design Category "B", Service Class "0") CE AS 4991 (See www.WPG.com for more information.)	
Based on product information at time of publication. Environmental conditions can affect product performance and longevity; consult the product instructions on WPG.com or contact a Technical Sales Representative for more information.		

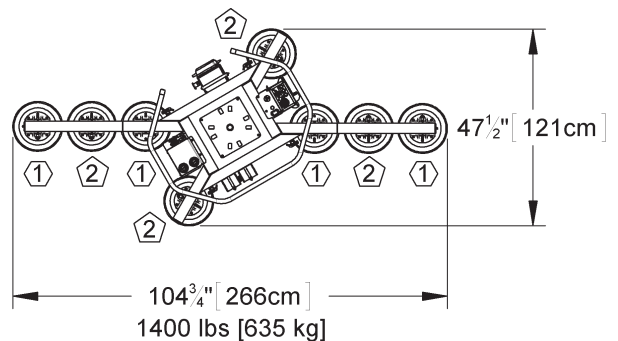
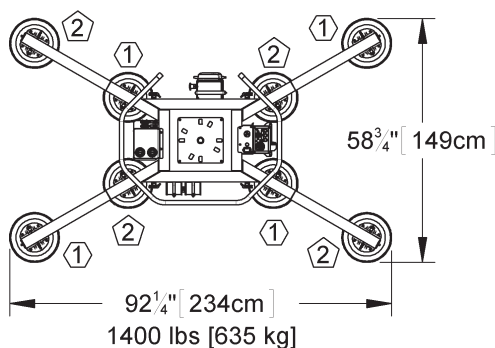
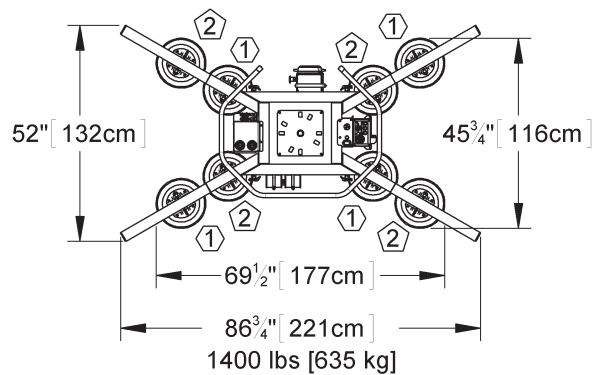
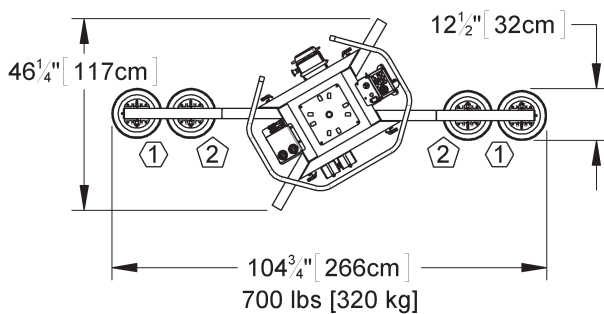
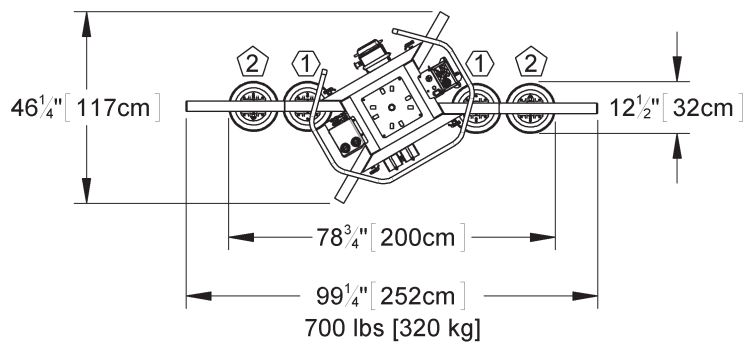
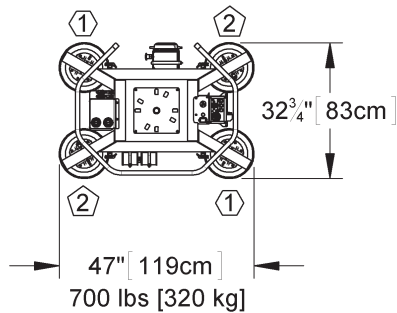

Model MRTA811LDC2 shown here.