

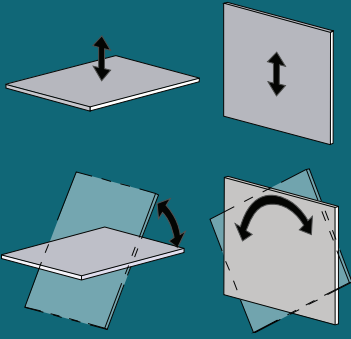

P11104DC3
700 lbs [320 kg]



**THE ORIGINAL
& TRUSTED NAME
IN VACUUM LIFTING
EQUIPMENT**

800.548.7341
WPG.com

908 West Main - P.O. Box 368
Laurel, Montana 59044 U.S.A.
406.628.8231 (phone)
406.628.8354 (fax)



Wood's Powr-Grip products are sold through authorized dealers.

WOOD'S POWR-GRIP® CHANNEL LIFTER P1 WITH DC3 DUAL VACUUM SYSTEM

Employing state-of-the-art technology, *Intelli-Grip®* automatically monitors vacuum and power systems to:

- Maximize productivity
- Help reduce human error
- Simplify maintenance and repairs
- Protect employees and property from harm



Maximum Load Capacity	700 lbs [320 kg]
Intelli-Grip® Technology	Automatic self-testing ensures lifter is ready for use, every lift. Color display provides critically relevant information at a glance. Anticipates threats and alerts operator beforehand with clearly visible and audible warnings. Continuously monitors battery and prevents lifter from attaching to loads if energy is hazardously low. Multiple alarm levels plainly identify the severity of hazards.
Load Movement	Manual rotation, 180° edgewise, with locking at each 1/4 turn Manual tilt, 90° between upright and flat, with automatic latching in upright position (in center rotation position, as shown on drawings)
Standard Operating Power	12 volts DC, 5 amps
Standard Features	Intelli-Grip® Technology Adjustable-position lift spool Dual vacuum system High-flow vacuum pump Battery and charger Battery energy gauge Low vacuum strobe light Low vacuum/power loss warning buzzer with back-up battery Green lift light Vacuum gauges Vacuum line filters Vacuum reserve tanks Blow-off for quick release Two-action, push-button release
Available Options	Remote control system (59906) Shipping case (53005) Alternative vacuum pads (Specifications not as listed above. Please contact us for more information): 9" [23 cm] diameter pad (VPFS9) 10" [25 cm] diameter, lipped pad (HV11) 10" [25 cm] diameter concave pad (G0750) 10" [25 cm] diameter pad with replaceable sealing ring (VPFS10T) Alternative pad compounds for low-marking, temperature resistant and coated surface applications (special order) Counterbalance Lifter (CB2DCS)
Dual Vacuum System	Features two completely independent vacuum circuits. Provides vacuum system redundancy. Limits possibility of a catastrophic failure. Reduces chance of harm to personnel or equipment.

Number / Size of Pads	4 / 11" [28 cm] diameter, lipped pads
Standard Pad Spread	51" x 12" [130 x 30 cm]
Lifter Weight	95 lbs [44 kg]
Design Standards	ASME B30.20 (BTH-1 Design Category "B", Service Class "0") CE AS 4991 (See www.WPG.com for more information.)

Based on product information at time of publication. Environmental conditions can affect product performance and longevity; consult the product instructions on WPG.com or contact a Technical Sales Representative for more information.

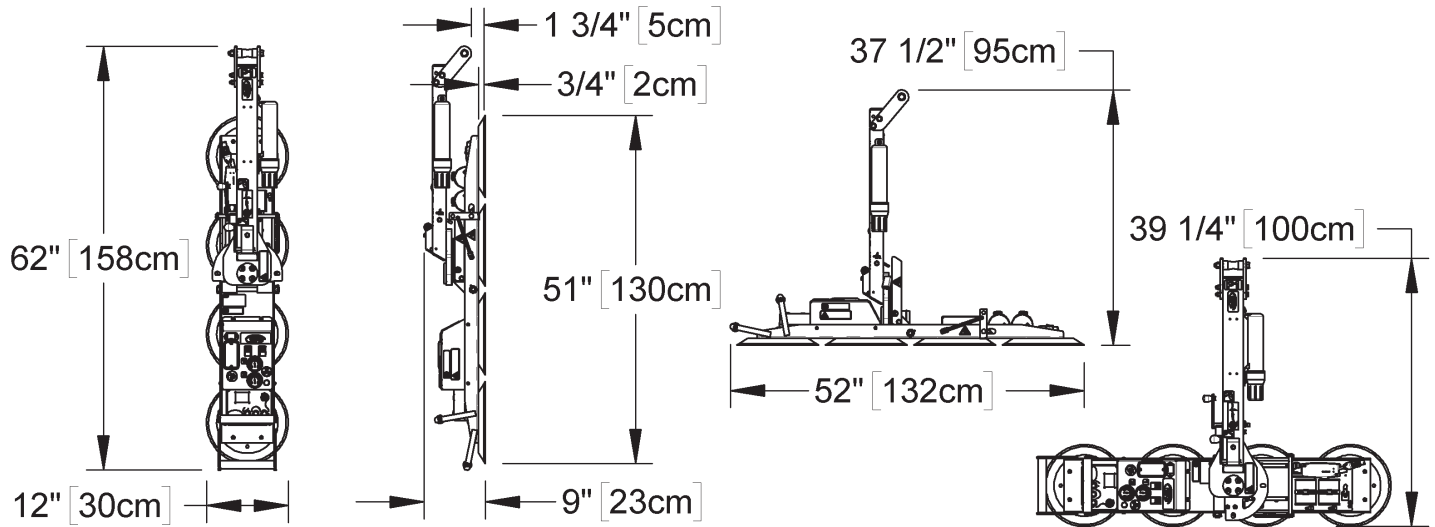

Shipping Case for P1 Vacuum Lifters

(lifter and case sold separately)

Designed specifically for shipping and storing all Powr-Grip® P1-04 Series Vacuum Lifters.

Durable thermo-formed ABS construction.

Three straps on inside of case hold vacuum lifter firmly in place.

Eight plastic buckles attached to nylon straps hold case in closed position.

Handles molded into the case structure enable convenient handling.

Ribbed exterior of case enables easy stacking of multiple lifters.

Case design incorporates grooves on the bottom to facilitate forklift handling.

