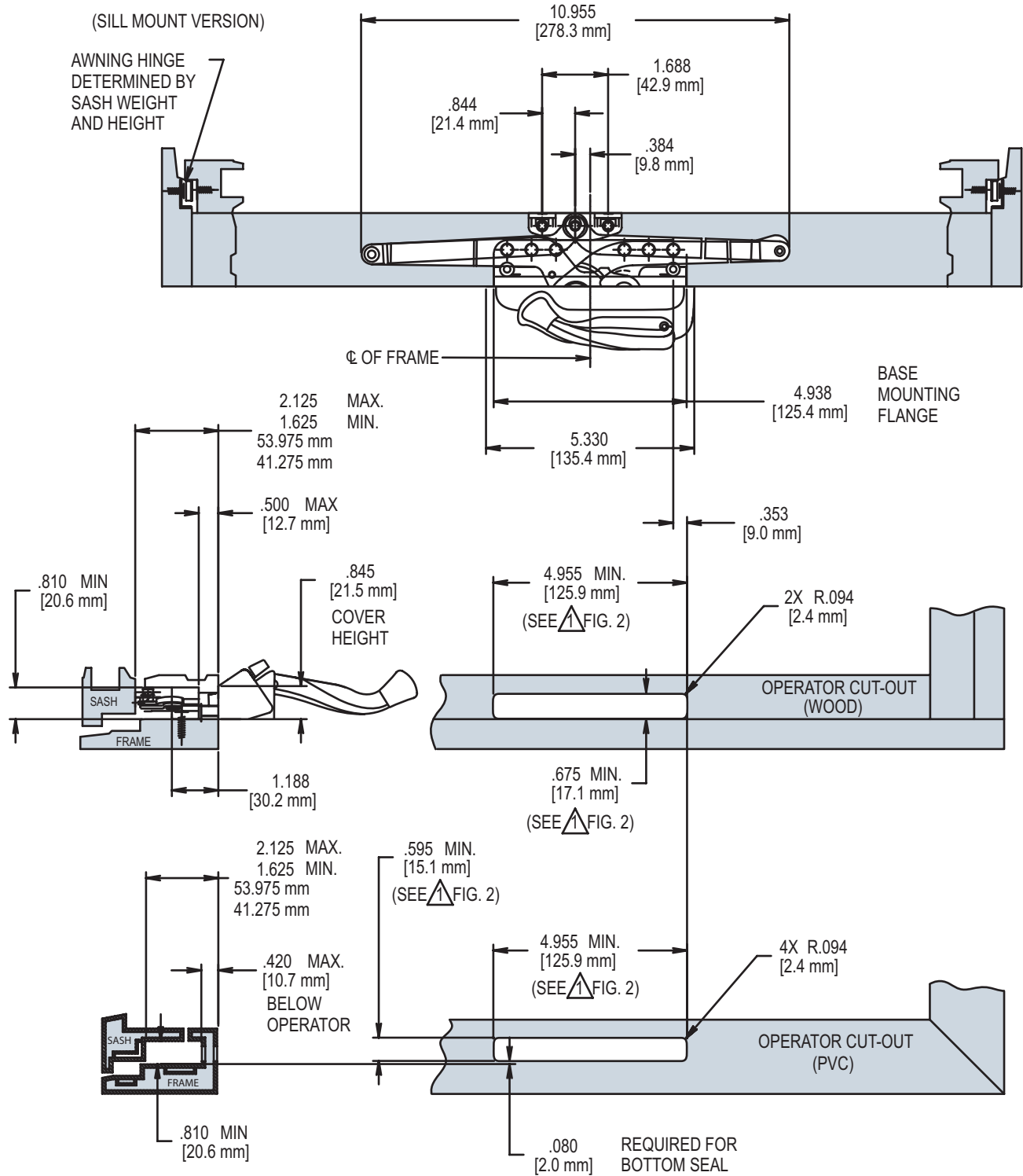
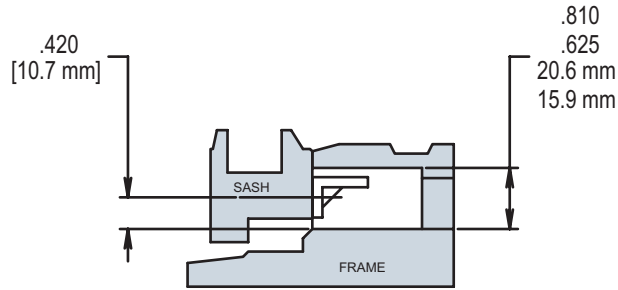

**FIG. 1 APPLICATION OF ENCORE NARROW AWNING OPERATOR**



# ENCORE™ AWNING OPERATOR (SILL MOUNT)

FIG. 2 APPLICATION OF ENCORE NARROW AWNING OPERATOR (CONTINUED)



BRACKET PLACEMENT

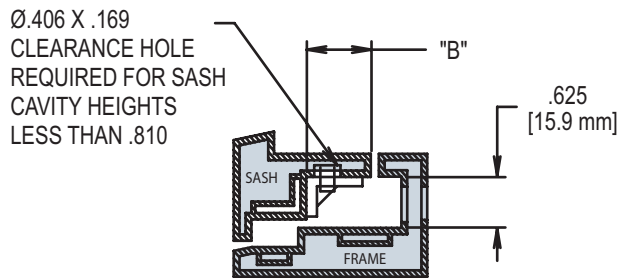

BRACKET PLACEMENT

HARDWARE SHOWN SEE FIG. 1

PART NUMBER	DESCRIPTION
51.11.XX.011	AWNING OPERATOR
22143	BRACKET
13.XX.XX.XXX	HINGE
12614.XX	TANGO HANDLE/COVER PACK
32658	GASKET (PVC)

NOTE:

⚠ HOLD THIS DIMENSION AS CLOSE TO THE MINIMUM AS MANUFACTURING TOLERANCES ALLOW. A CLOSE FITTING CUT-OUT HELPS TO STABILIZE THE OPERATOR AGAINST ROCKING

2. USE 32658 GASKET ON PVC AND METAL PROFILES
3. ALL AWNING OPERATORS USE 12614.XX LEFT HAND TANGO HANDLE/COVER PACK
4. MINIMUM RECOMMENDED SASH HEIGHT 16" (DEPENDENT ON PROFILE)
5. SASH OVERHANG "B" SHOULD BE AS SMALL AS POSSIBLE  
BRACKET MAY NEED TO BE MOUNTED CLOSER TO SASH EDGE TO ELIMINATE BRACKET DETACH AT FULL OPEN ON SHORT SASH SIZES

**FIG. 3 ENCORE NARROW AWNING OPERATOR (SILL MOUNT VERSION)**

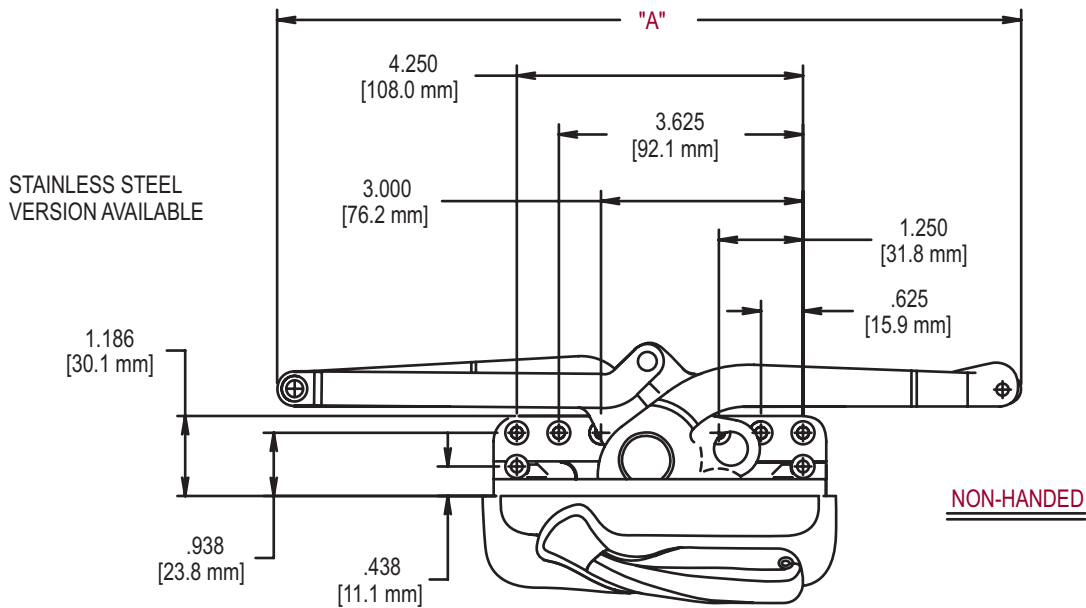

**RECOMMENDED SCREWS:**

(QTY 6)(P/N 19240.XX)#8 X 1.0 PHILLIPS,  
FLAT HEAD,SHEET METAL SCREWS  
(SEE TRUTH TIPS FOR MORE INFORMATION)

PART NO.	"A"	APPROXIMATE AMOUNT OF OPENING
51.11	11"	8"



**FIG. 4 BRACKET 22143**

**NOTE:**

1. BRACKET IS SUPPLIED  
WITH OPERATOR. DO  
NOT ORDER SEPARATELY

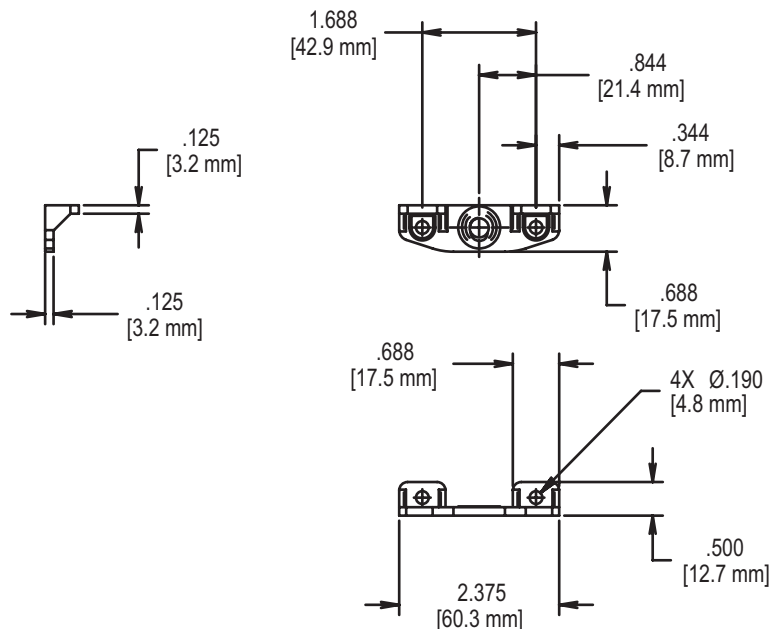

**RECOMMENDED SCREWS:**

(QTY 2)(P/N 19230.XX)#8 X 1.0 PHILLIPS,  
PAN HEAD, SHEET METAL SCREWS  
(SEE TRUTH TIPS FOR MORE INFORMATION)