



Deglazing Tool

Instructions for Use, Maintenance and Care

Rev. 0.1 / 06-18 Instruction Sheet 32608 **DG**

PARTS

1.	90154AM	Plunger Assembly, ABS
2.	49486T	Vacuum Pad, 8" Dia., Flat (G0695)
3.		Red Line
4.	10002	Screw, 1/4-20 x 1/2"
5.	90151	Handle / Valve Assembly, ABS
6.		Valve Release Lever
7.		Handle Grip, 1" ID
8.		30" Pry Bar
9.	10080	1/4-20 x 1/2" Thumb Screw
10.	13512	3/8" x 2" Cotterless Hitch Pin
11.	13520	3/8" x 3" Cotterless Hitch Pin
12.		4-1/4" Pressure Pad (standard)
13.		18" Wide-Base Pressure Pad (optional)

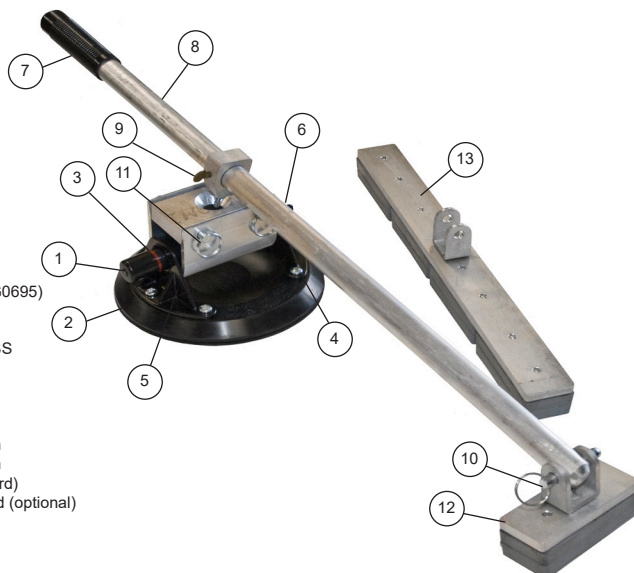

SPECIFICATIONS

Product Description

The Deglazing Tool uses a vacuum cup and lever to remove nonporous objects, such as mirrors and windows, from their mounting locations, as follows: A manual pump removes air from between the vacuum pad and the contact surface; a red line on the pump's plunger serves as a vacuum indicator; a check valve allows the user to repump the cup without removing it from the contact surface; and a valve release lever allows the cup to disengage completely. A pry bar and pressure pad attached to the cup provide leverage to pull objects from their mounting locations.

Environmental Conditions

Use on clean, relatively smooth, nonporous surfaces, at temperatures from 10° to 120° Fahrenheit [-12° to 49° Celsius]. Moisture or contaminants can reduce the slip resistance of the vacuum cup. The red-line indicator may not perform reliably at elevations above 5000 feet [1524 meters]; see Service.

ASSEMBLY

The Deglazing Tool comes fully assembled and ready-to-use, with the standard 4 1/4" [10.8 cm] pressure pad. However, an optional 18" [45.8 cm], wide-base pressure pad can be used to distribute pressure over a larger surface area (preferably over more than one stud or support beam). To switch pressure pads, remove the cotterless hitch pin, exchange the pressure pads and reinstall the pin.

OPERATION

To Attach Cup

- 1) Clean the contact surface of the object you wish to remove and, if needed, the face of the vacuum cup (see Cleaning). CAUTION: Test the cup and pressure pad for staining or deformation of surfaces with light colors or soft coatings.
- 2) Position the vacuum cup on the object close to the mastic or adhesive location, so the red line will be visible if it should appear while using the Deglazing Tool.
- 3) Pump the plunger until the cup attaches completely and the red line is hidden. Check the plunger periodically to make sure the cup remains securely attached. If the red line appears, pump the plunger until the red line is hidden again (see WARNINGS).

To Remove Object

- 1) Loosen the thumb screw and slide the vacuum cup along the pry bar as necessary to orient the pressure pad over a stud in the wall or at a location which will not bend, dent or otherwise become damaged while using the Deglazing Tool. Then tighten the thumbscrew.
- 2) Pull on the pry bar with increasing pressure until the adhesive or mastic holding the object begins to release. CAUTION: Jerking on the pry bar may cause rapid release of adhesives, resulting in damage to the Deglazing Tool or injury to the user.
- 3) Reposition the vacuum cup and pressure pad as necessary to completely remove the object from its mounting location.

To Release Cup

- 1) Secure the Deglazing Tool, to prevent it from falling when the vacuum cup is released.
- 2) Press the valve release lever until the cup disengages completely.

MAINTENANCE

Service

Since aging and wear reduce the capacity of the vacuum pad, it should be replaced at least once every 2 years or whenever damage is discovered (see Inspection).

If the vacuum cup does not function normally (see Inspection), the cup face may be dirty or the cup may require service. First clean the cup face according to the directions to follow. If the condition persists, contact an authorized dealer or visit www.WPG.com for assistance.

Cleaning

- 1) Remove the air filter from the cup face.
- 2) Use a clean sponge or lint-free cloth to apply soapy water or another mild cleanser to the cup face; see WARNINGS and www.WPG.com for more information. CAUTION: To prevent liquid from contaminating the pump, hold the cup face-down or cover the suction hole in the filter recess.
- 3) Wipe all residue from the cup face.
- 4) Allow the cup to dry and reinstall the air filter.

Inspection

Examine and test the vacuum cup regularly to make sure it does not exhibit the following faults:

- cuts or damage to sealing edges of vacuum pad.
- cracks or dents in handle, weldment or pump.
- reappearance of red line soon after attaching cup.
- sluggishness or dramatic changes in pump action.
- excessive glaze or stiffness of vacuum pad.
- air filter missing from cup face.

Correct any faults before using the Deglazing Tool (see Service).

Storage

Store the Deglazing Tool in a clean, dry location out of direct sunlight. Protect the vacuum pad from damage using the cover or another appropriate means.

WARNINGS

Failure to observe WARNINGS could damage the Deglazing Tool or cause injury to the user.

- Do not operate the tool if it is damaged, malfunctioning or missing parts.
- Do not place the face of the vacuum cup against surfaces which could damage the sealing edges.
- Avoid conditions that could cause the cup to slip or to disengage prematurely, such as: contaminants, cuts or scratches in the cup face or contact surface; attaching the cup to porous or cracked materials; or applying pressure against the cup edge.
- Do not pry on the object when the red line is visible. If the red line reappears frequently, discontinue use and see Service.
- Position yourself and others to avoid injury if the cup disengages or the object dislodges unexpectedly.
- Do not allow anything to interfere with free movement of the plunger while the cup is attached.
- Do not touch the valve release lever while applying pressure to the pry bar.
- Do not use harsh chemicals (such as solvents or gasoline) or unauthorized rubber cleaners and conditioners to clean the cup.
- Protect all surfaces which could be damaged in case of an unexpected load release or material breakage.





Limited Warranty

Instructions for Use,
Maintenance and Care

PARTS

- | | |
|------------|---------------------------------------|
| 1. 90154AM | Plunger Assembly, ABS |
| 2. 49486T | Vacuum Pad, 8" Dia., Flat (G0695) |
| 3. | Red Line |
| 4. 10002 | Screw, 1/4-20 x 1/2" |
| 5. 90151 | Handle / Valve Assembly, ABS |
| 6. | Valve Release Lever |
| 7. | Handle Grip, 1" ID |
| 8. | 30" Pry Bar |
| 9. 10080 | 1/4-20 x 1/2" Thumb Screw |
| 10. 13512 | 3/8" x 2" Cotterless Hitch Pin |
| 11. 13520 | 3/8" x 3" Cotterless Hitch Pin |
| 12. | 4-1/4" Pressure Pad (standard) |
| 13. | 18" Wide-Base Pressure Pad (optional) |

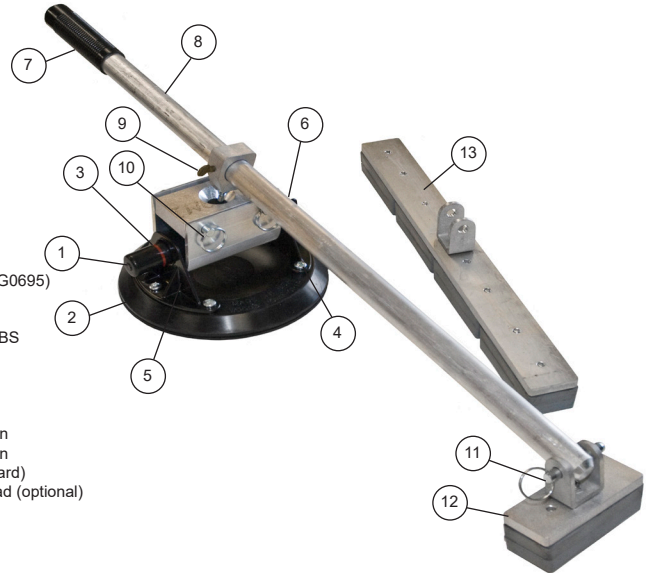

LIMITED WARRANTY

Wood's Powr-Grip vacuum cups are carefully constructed, thoroughly inspected at various stages of production, and individually tested. They are warranted to be free from defects in workmanship and materials for one year from the date of purchase. If a problem develops during the warranty period, return the complete product as directed below. If inspection shows that the problem is due to defective workmanship or materials, the product will be repaired or replaced without charge.

WARRANTY DOES NOT APPLY WHEN:

- Rubber portions have been cut or scratched during use.
- Repairs are required due to abnormal wear and tear.
- The product has been abused, misused or neglected.
- Alterations have been made to the product.

A problem not covered under warranty will be corrected automatically, unless the customer includes a written request for notification of costs prior to repair. Otherwise the customer assumes all responsibility for repair costs and agrees to receive the repaired product on a C.O.D. basis.

TO OBTAIN WARRANTY SERVICE

For purchases in **North America:**

- Please include your name, address and phone number;
- Indicate **WARRANTY RETURN**;
- Ship product—prepaid—**DIRECTLY TO MANUFACTURER** at:
Wood's Powr-Grip Co., Inc.
908 West Main
Laurel, MT 59044 U.S.A.

For purchases in **all other localities:**

- Return product to point of purchase.

**DO NOT MAIL THIS WARRANTY TO WOOD'S POWR-GRIP.
RETAIN THIS INFORMATION FOR YOUR RECORDS.**

Purchased From	Model No.
Date Purchased	Serial No. (if present)